

Relational Control:

More Efficient and Effective Control for the 21st Century

ASHRAE
B.C. & Vancouver Island
Chapters
October 18 & 19, 2006

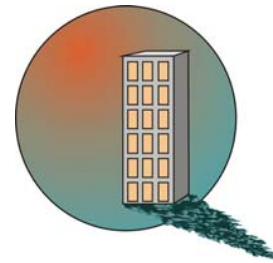

Tom Hartman, P.E.
The Hartman Company
Georgetown, Texas
www.hartmanco.com
E-mail: tomh@hartmanco.com

Presentation Agenda

1. HVAC Loads: The load requirements of cooling systems in typical HVAC applications
2. Variable Speed: Performance characteristics as applied to HVAC components
3. Relational Control: A replacement for PID to leverage the full advantage of variable speed and network controls applied to HVAC applications
4. Project Process: The need to revise design / construction / startup / turnover process when contemplating newer technologies aimed at improving system performance.
5. Discussion

Characteristics of Comfort Cooling Loads for Climate Types

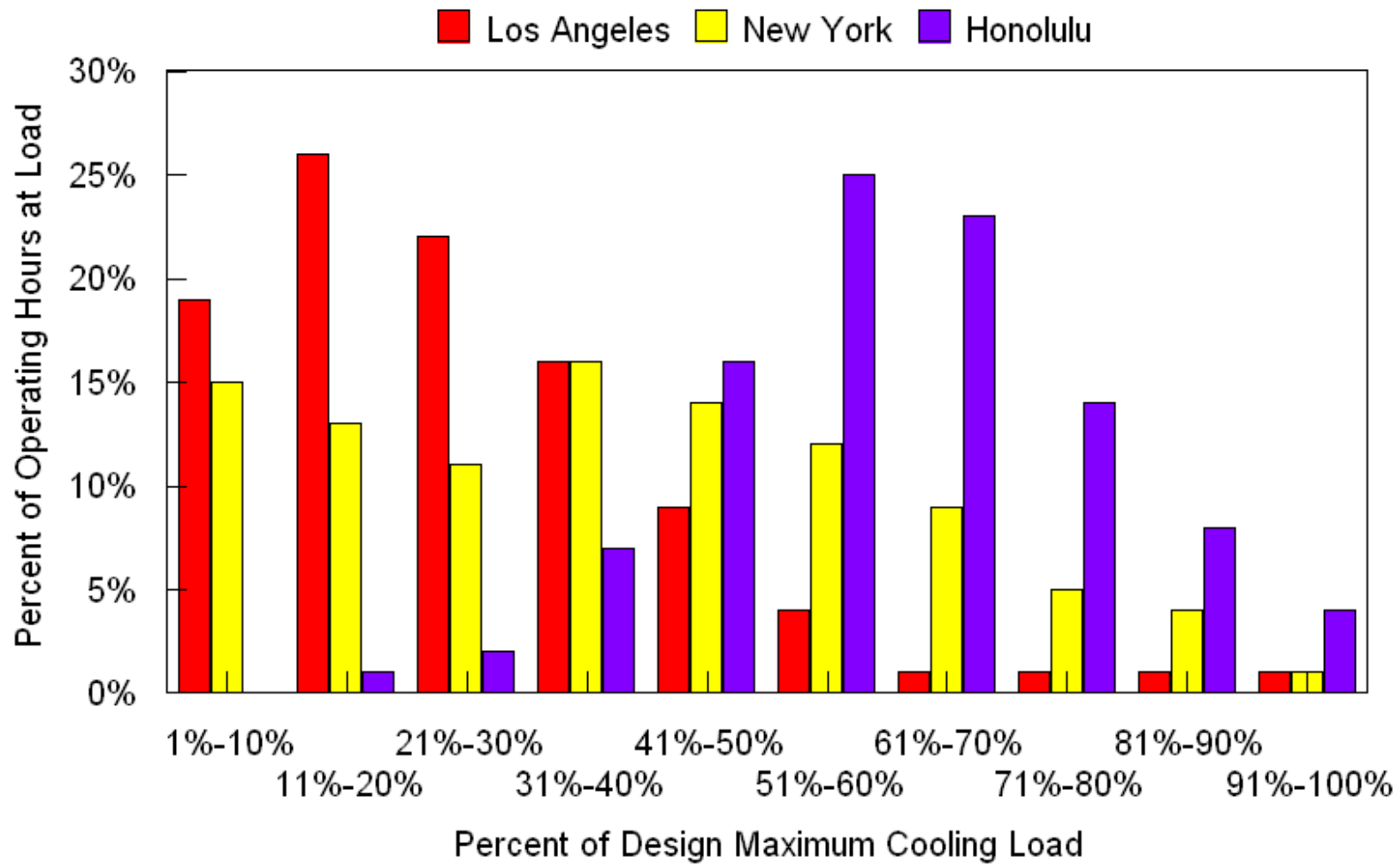

Variable Speed Laws

For Fans, Pumps & Chiller Compressors

- Flow (Capacity) is proportional to the speed
- Head is proportional to the speed squared
- Power is proportional to the speed **cubed**

Important Considerations when applying VS

1. To achieve this power reduction, the head requirement of the fan, pump or compressor must be reduced at lower loads.
2. The efficiency of VS equipment improves significantly as capacity falls below 100%.

Variable Speed Fan & Pump Operation

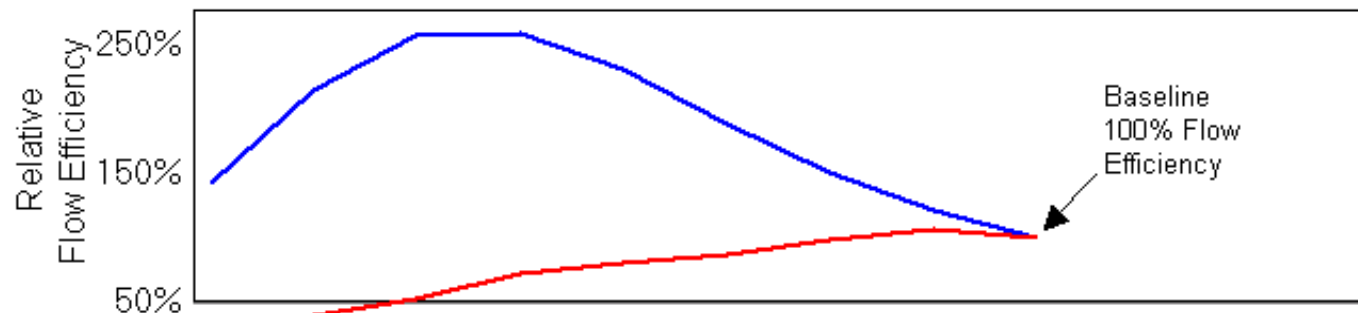
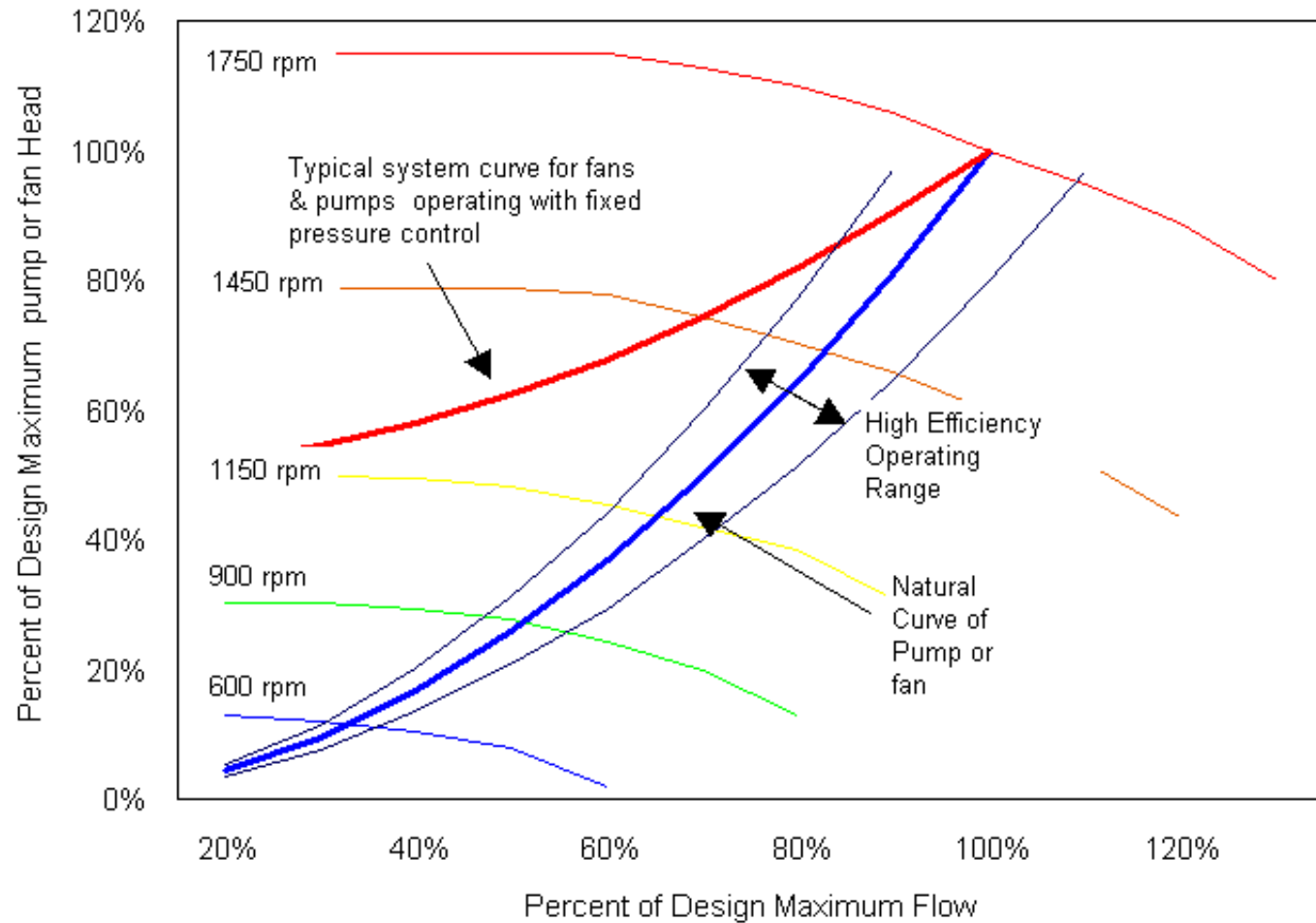

Problems with PID in Variable Speed Applications

1. The single controlled variable feature of PID control makes it difficult to capture the entire power reduction opportunities for part load operation of VFD components.
2. The independent nature of PID control modules makes it difficult to coordinate the components within multi-component systems in order to obtain optimal operation at all operating conditions.

Conventional HVAC Central System Control

Under PID control, each system component is operated independently to maintain a setpoint (usually pressure or temperature) that does not necessarily reflect the current requirements of the system

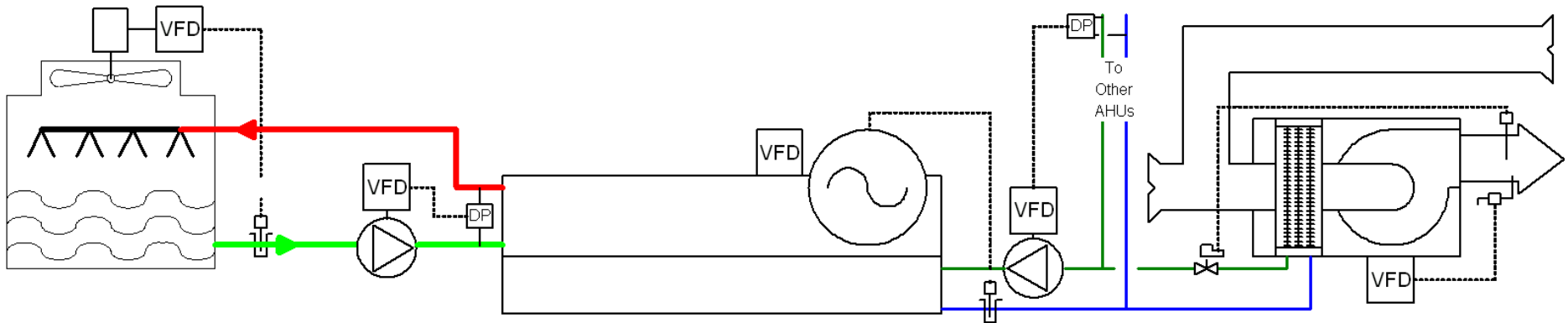

PID is a primitive means of controlling system capacity . Controllability and stability are almost always issues with PID control . Energy optimization of any range of conditions almost always adds to these controllability and stability issues . Furthermore energy optimization is constrained by precision and accuracy of the intermediate temperature and pressure instrumentation .

The Equal Marginal Performance Principle

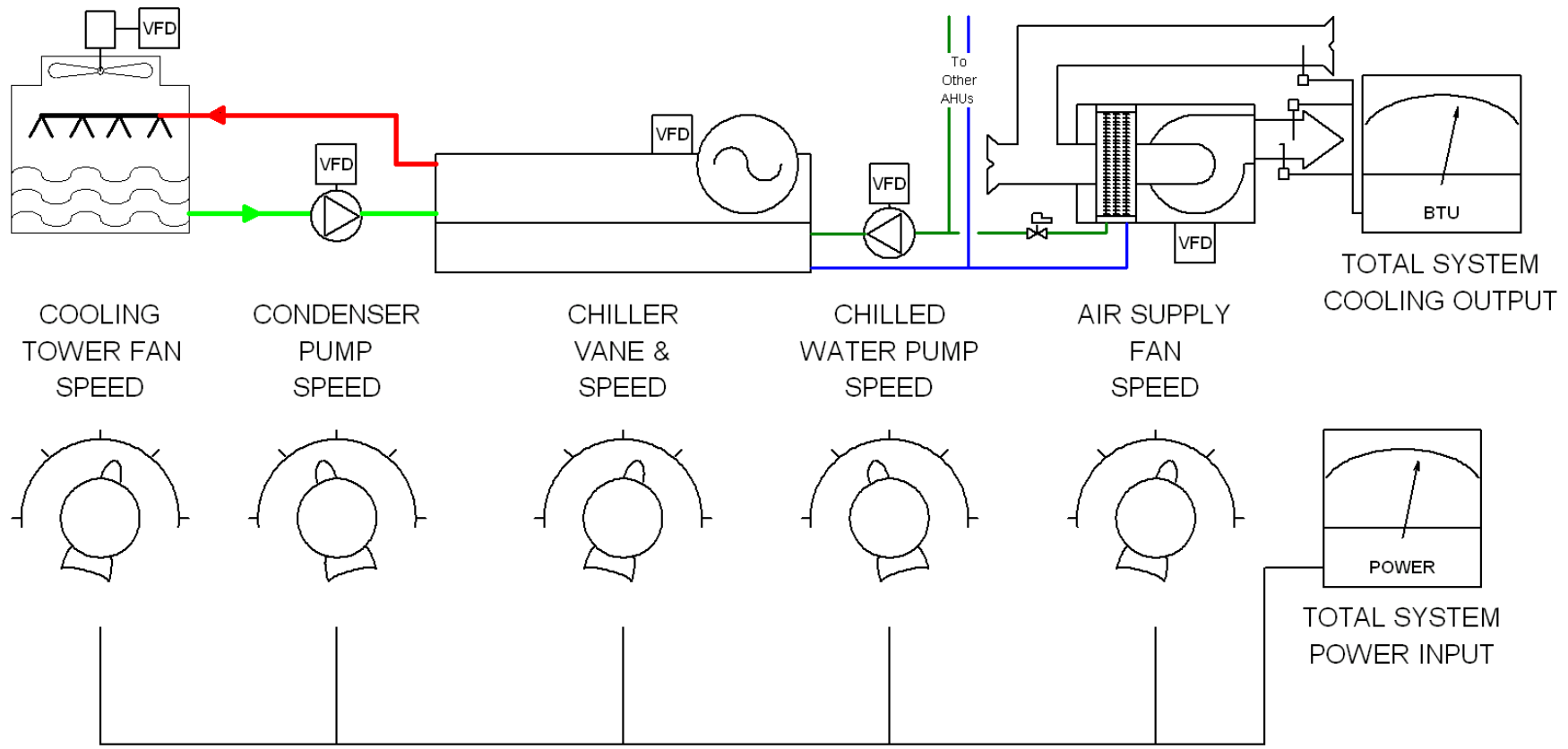

The Equal Marginal Performance Principle

The Equal Marginal Performance Principle states that the energy performance of any system operating with multiple modulating components is optimized when the marginal system output per unit energy input is the same for all individual components in the system.

"PID" Control Loop

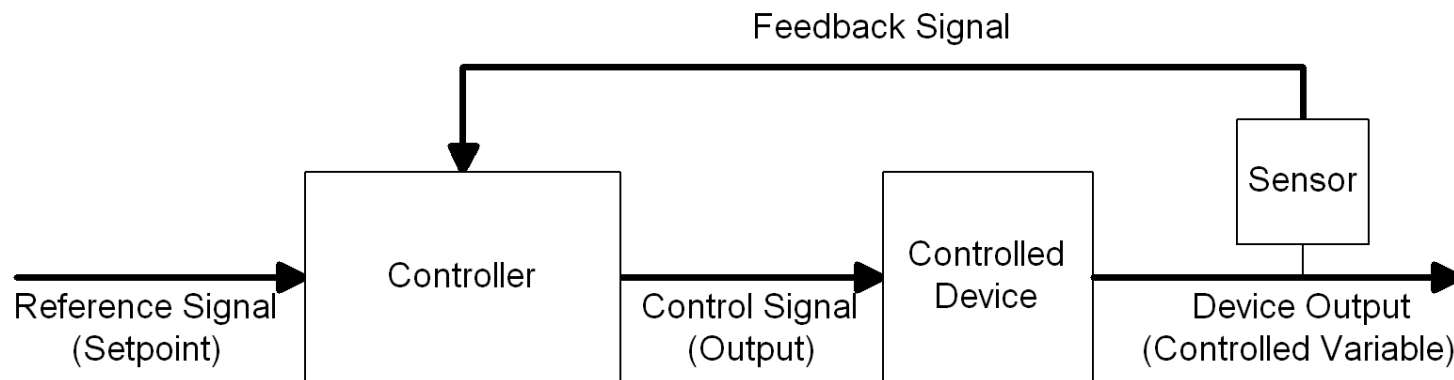

P = Proportional

I = Integral

D = Derivative

HVAC Control Options With DDC Controls

HVAC CONTROL OPTIONS			
TYPE OF CONTROL	Classical Feedback Control	Relational Control	
CONTROL NAME	Proportional , Integral ,Derivative (PID) Control	Demand Based Control	Intelligent Iterative Control
CONTROL PROCESS	Control Based on Feedback from Controlled Variable	Control based on optimal power relationships among system components	Control based directly on condition of components served
BASIS OF CONTROL	Analog proportional control	Equal marginal performance principle	Iterative problem solving
MAXIMUM RESPONSE TIME INTERVAL	0.1 to 5.0 Seconds	0.5 to 5.0 Minutes	0.5 to 5.0 Minutes
ENERGY OPTIMIZATION	Energy optimization is not feasible within control loop over entire operating range . Requires separate step	Energy optimization is the basis and therefore inherent in this type of control	Energy optimized relationships are recommended in developing control algorithms
EXAMPLE	Standard temperature or pressure setpoint control	All-variable speed chilled water plant under demand based control	Valve orifice area method of distribution pump control

Demand Based Control

Demand Based Control is a method of relational control developed for systems that incorporate multiple modulating components to achieve a desired result or condition. It replaces multiple stand alone PID loops that operate each component independently.

Demand Based Control

Demand based control is a relational method of control that has been developed from the Equal Marginal Performance Principle. Demand based control operates individual components based on relative power input rather than to maintain an intermediate temperature or pressure setpoints.

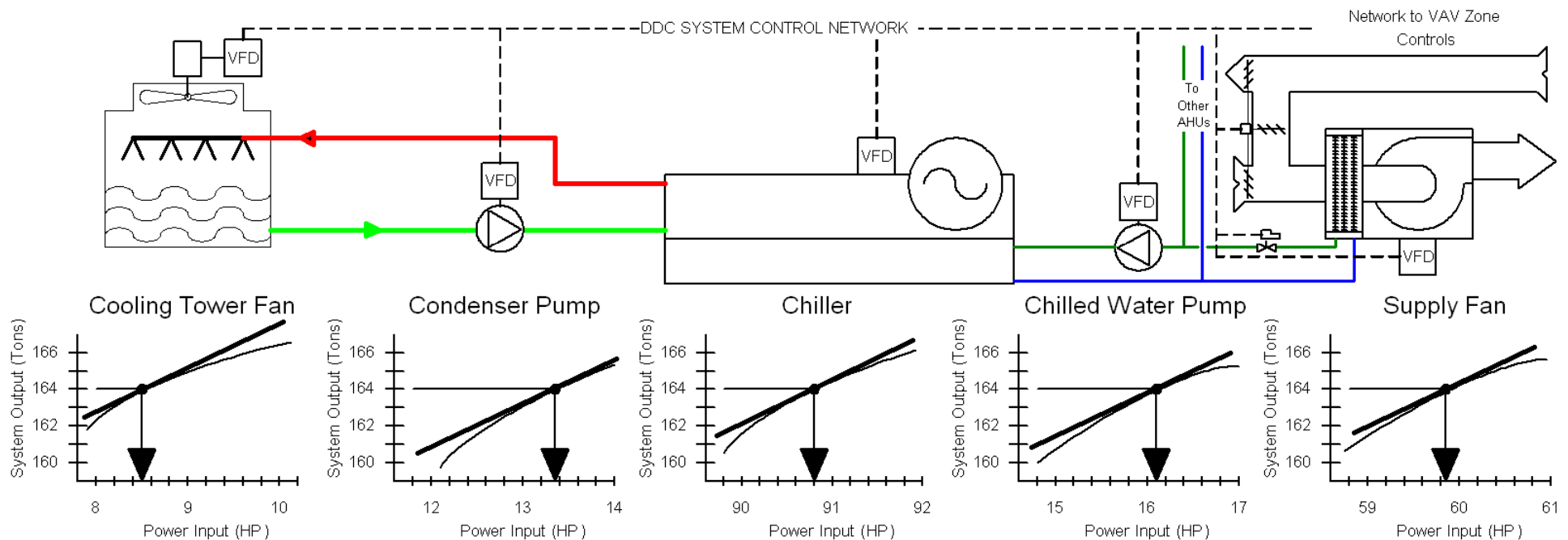

Because continuous error correction is not an essential element of demand based control, operating stability is almost never an issue. The above system is optimized at the relative power settings shown by the arrows because, in accordance with the Equal Marginal Performance Principle, the marginal performance (slope of the curve of total system output per unit input for the component) is the same for all system components.

Features of Demand Based Control

- A method of "relational control" that does not require continuous feedback in operation
- Employs control network to gather information from all components in the system to develop control for each of them
- Control cycle times are typically 30 seconds to several minutes
- Pumps and fans do not maintain a specific pressure setpoint. Pressure can drop more quickly as flow requirements are reduced.

Iterative Control

Iterative control is a relational control method that applies iterative problem solving techniques in control applications.

The Iterative Control process incorporates the use of an algorithm that approximates the control of a component in relation to a variety of parameters that affect its performance and desired outcome. With each iteration, the algorithm is adjusted and reapplied to provide stable and effective control.

PID Control of a CHW Distribution System

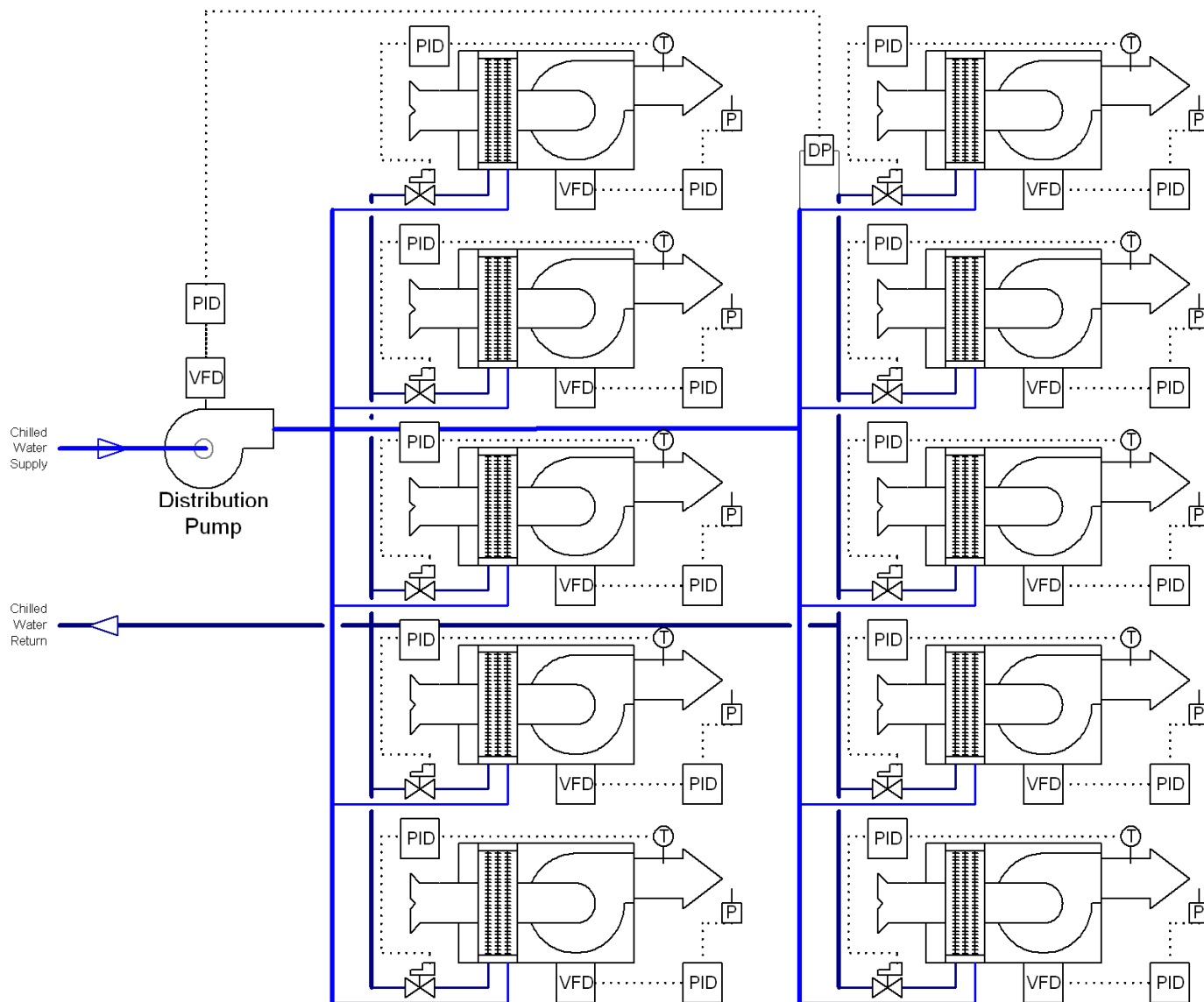

Under PID Control each valve is modulated to maintain an air temperature setpoint independently of fan flow. For this control, valve authority requirements mandate that 25% to 50% of total pressure drop at full load occur across the valves.

The distribution pump is operated to maintain a differential pressure setpoint that includes both valve and load (coil) full load pressure losses. Energy use is significantly higher than necessary to obtain desired flow, especially at part load conditions.

Iterative Control of a Distribution System

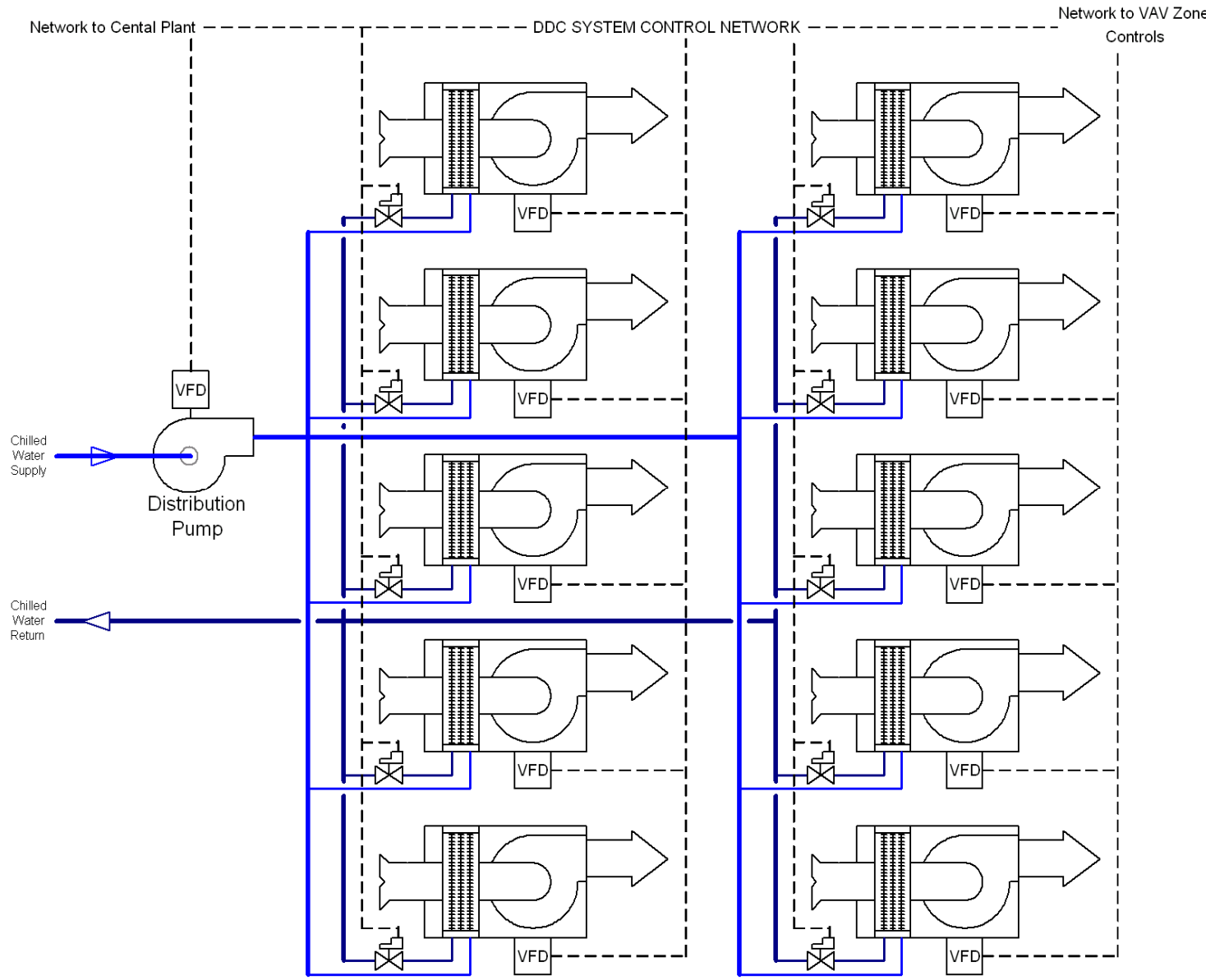

Under Iterative Control valves are line sized for minimal pressure drop at full flow. AHU cooling coil valves are modulated with iterative control to maintain optimal fan speed (power) relationships with other elements of the system. Pump energy requirements are greatly reduced because of the low pump pressure requirement at all loads.

The iterative pump control strategy is to maintain a constant low velocity through all valves. The distribution pump speed is controlled according to total valve orifice area.

Hurdles in Implementing Relational Control Focused on System *Performance*

1. Lack of continuity between design - procurement – construction - startup - operation stages of projects.
2. Lack of communication among project participants.
3. Lack of understanding of performance requirements.
4. Lack of responsibility for achieving system performance goals.
5. Lack of ability to correct problems that adversely affect system performance.

Why Implement Relational Control?

1. Efficiency Improvements
2. Performance Improvements
3. Simpler Configurations and Simpler Control
4. More Stable Operation
5. Reduced Maintenance Requirements
6. Social and Professional Imperative

Summary

Relational control leverages variable speed and network control to offer significantly improved operating efficiency and other benefits over systems using conventional control.

Relational control provides a straightforward path to optimize both the design and operation of HVAC systems.

The next step to move forward and capture the benefits is to initiate industry wide discussions and determine how we can best support progress toward more advanced relational control technologies.

Relational Control:

More Efficient and Effective Control for
the 21st Century

Questions, Comments, Discussion

ASHRAE
B.C. & Vancouver Island
Chapters
October 18 & 19, 2006

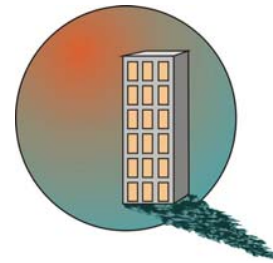

Tom Hartman, P.E.
The Hartman Company
Georgetown, Texas
www.hartmanco.com
E-mail: tomh@hartmanco.com